

1.425V to 3.6V Input, 2A, 0.2V Dropout LDO Regulators

General Description

The MAX8526/MAX8527/MAX8528 low-dropout linear regulators operate from input voltages as low as 1.425V and are able to deliver up to 2A of continuous output current with a maximum dropout voltage of only 200mV. The output voltage can be set from 0.5V to ($V_{IN} - 0.2V$) and is 1.4% accurate over load and line variations, from 0°C to +85°C.

These regulators use small, 2.2 μ F ceramic input capacitors and 10 μ F ceramic output capacitors to deliver 2A output current. High bandwidth provides excellent transient response and limits the output voltage deviation to 45mV for a 20mA to 2A load step, with only a 10 μ F ceramic output capacitor, and the voltage deviations can be reduced further by increasing the output capacitor.

Designed with an internal P-channel MOSFET pass transistor, the MAX8526/MAX8527/MAX8528 feature low 500 μ A typical supply current during dropout conditions. Soft-start reduces inrush current. Other features include a logic-controlled shutdown mode, short-circuit protection, and thermal-overload protection.

The MAX8527 features a power-OK (POK) output that transitions high when the regulator output is within $\pm 10\%$ of its nominal output voltage. The MAX8528 features a 150ms power-on reset (POR) output.

The parts are packaged in a 14-pin TSSOP package, which includes an exposed pad for optimal power dissipation.

Applications

Servers
Networking
Storage
Base Stations
Optical Modules
Post Regulators
Notebooks
PDAs
ATE

Pin Configurations appear at end of data sheet.

Features

- ◆ 1.425V to 3.6V Input Voltage Range
- ◆ Guaranteed 200mV Dropout at 2A Output Current
- ◆ $\pm 0.6\%$ Initial Accuracy
- ◆ $\pm 1.4\%$ Output Accuracy over Load/Line/Temperature (0°C to +85°C)
- ◆ Compatible with Ceramic Capacitors
- ◆ Fast Transient Response
- ◆ 440 μ A Operating Supply Current
- ◆ <50 μ A Shutdown Supply Current
- ◆ Short-Circuit Protection
- ◆ Thermal-Overload Protection
- ◆ Soft-Start Limits Inrush Current
- ◆ 5mm x 6.4mm Footprint, 1.1mm Profile

Ordering Information

PART	TEMP RANGE	PIN-PACKAGE
MAX8526EUD	-40°C to +85°C	14 TSSOP
MAX8526EUD+	-40°C to +85°C	14 TSSOP
MAX8527EUD	-40°C to +85°C	14 TSSOP
MAX8527EUD+	-40°C to +85°C	14 TSSOP
MAX8528EUD	-40°C to +85°C	14 TSSOP
MAX8528EUD+	-40°C to +85°C	14 TSSOP

+ Denotes lead-free packaging.

Typical Operating Circuit

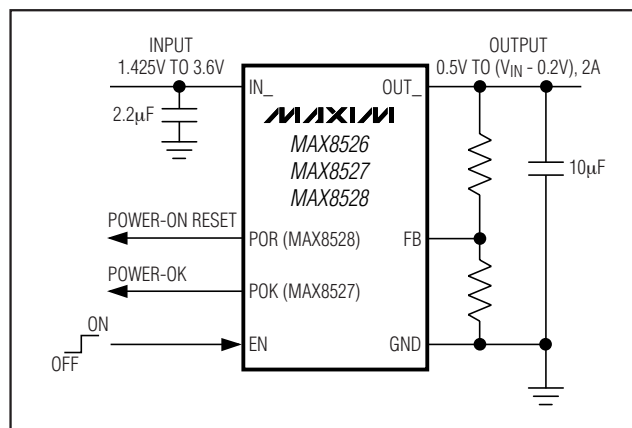

1.425V to 3.6V Input, 2A, 0.2V Dropout LDO Regulators

ABSOLUTE MAXIMUM RATINGS

IN, EN, POK (MAX8527), POR (MAX8528),
 FB to GND-0.3V to +4.0V
 OUT to GND-0.3V to (IN + 0.3V)
 Output Short-Circuit Duration.....Continuous
 Continuous Power Dissipation (T_A = +70°C,
 EP soldered to PC board ground)
 14-Pin TSSOP (derate 20.8mW/°C above +70°C).....1.7W

Operating Temperature Range-40°C to +85°C
 Junction Temperature.....+150°C
 Storage Temperature Range-65°C to +150°C
 Lead Temperature (soldering, 10s).....+300°C

Stresses beyond those listed under "Absolute Maximum Ratings" may cause permanent damage to the device. These are stress ratings only, and functional operation of the device at these or any other conditions beyond those indicated in the operational sections of the specifications is not implied. Exposure to absolute maximum rating conditions for extended periods may affect device reliability.

ELECTRICAL CHARACTERISTICS

(Circuit of Figure 1: V_{IN} = +1.8V, V_{OUT} = +1.5V, EN = IN, I_{OUT} = 2mA, T_A = -40°C to +85°C, unless otherwise noted.) (Note 1)

PARAMETER	CONDITIONS	MIN	TYP	MAX	UNITS
IN					
Input Voltage Range		1.425		3.600	V
Input Undervoltage Lockout	V _{IN} rising, 70mV hysteresis	1.32	1.35	1.38	V
OUT					
Output Voltage Range		0.5		3.4	V
Load Regulation	I _{OUT} = 2mA to 2A		0.08		%/A
Line Regulation	V _{IN} = 1.425V to 3.6V, V _{OUT} = 1.225V, I _{OUT} = 2mA	-0.15	0	+0.15	%/V
Dropout Voltage (V _{IN} - V _{OUT})	V _{IN} = 1.425V, I _{OUT} = 2A, V _{FB} = 480mV		100	200	mV
Current Limit	V _{IN} = 3.6V, V _{OUT} = 3V, V _{FB} = 480mV	3.2	4	4.8	A
Output Shutdown Leakage	V _{IN} = 3.6V, V _{OUT} = 0, V _{EN} = 0		0.5	50	μA
FB					
FB Threshold Accuracy	I _{OUT} = 20mA, T _A = +85°C	497	500	503	mV
	V _{OUT} = 1.225V to 3V, V _{IN} = (V _{OUT} + 0.2V) to 3.6V, I _{OUT} = 2mA to 2A	493		507	
FB Input Bias Current	V _{FB} = 0.5V, V _{IN} = 3.6V		0.001	1	μA

1.425V to 3.6V Input, 2A, 0.2V Dropout LDO Regulators

MAX8526/MAX8527/MAX8528

ELECTRICAL CHARACTERISTICS (continued)

(Circuit of Figure 1: $V_{IN} = +1.8V$, $V_{OUT} = +1.5V$, $EN = IN$, $I_{OUT} = 2mA$, $T_A = -40^{\circ}C$ to $+85^{\circ}C$, unless otherwise noted.) (Note 1)

PARAMETER	CONDITIONS	MIN	TYP	MAX	UNITS	
GND						
GND Supply Current	$V_{IN} = 3.6V$, $V_{OUT} = 3V$, $I_{OUT} = 20mA$	440			μA	
	Dropout, $V_{IN} = 3.6V$, $V_{FB} = 480mV$	500	800			
GND Shutdown Current	$V_{IN} = 3.6V$, $EN = GND$	0.5	50		μA	
POK (MAX8527 only)						
Power-OK Threshold	V_{FB} moving out of regulation, $V_{HYS} = 10mV$, $I_N = 1.425V$ to $3.6V$	FB high	540	550	560	mV
		FB low	440	450	460	
POK Output Voltage Low	$V_{FB} = 0.4V$ or $0.6V$, $I_{POK} = 2mA$		25	200	mV	
POK Output Current High	$V_{POK} = 3.6V$		0.001	1	μA	
POK Fault Delay Time	From FB to POK	25	50	100	μs	
POR (MAX8528 only)						
Power-On Reset Threshold	V_{FB} falling, $V_{HYS} = 10mV$, $V_{IN} = 1.425V$ to $3.6V$	440	450	460	mV	
POR Output Voltage Low	$V_{FB} = 0.4V$ or $0.6V$, $I_{POR} = 2mA$		25	200	mV	
POR Output Current High	$V_{POR} = 3.6V$		0.001	1	μA	
POR Rising Delay Time	From FB to POR	105	150	210	ms	
EN						
Enable Input Threshold	$V_{IN} = 1.425V$ to $3.6V$	EN rising	1.2		V	
		EN falling	0.4			
Enable Input Bias Current	$V_{EN} = 0$ or $3.6V$	-1		+1	μA	
THERMAL SHUTDOWN						
Thermal-Shutdown Threshold	Output on or off	T_J rising	+165		$^{\circ}C$	
		T_J falling	+150			
OUTPUT TRANSIENT						
Load Transient	$I_{OUT} = 20mA$ to $2A$ to $20mA$, $t_{RISE} = t_{FALL} = 1\mu s$		3		%	
Line Transient	$\delta V_{IN} = 0.5V$, $t_{RISE} = t_{FALL} = 5\mu s$		3		%	

Note 1: Specifications to $-40^{\circ}C$ are guaranteed by design, not production tested.

Note 2: Measurements at high current are pulse tested, such that the junction temperature is ambient temperature. Minimum supply voltage for output accuracy must be at least 1.425V.

1.425V to 3.6V Input, 2A, 0.2V Dropout LDO Regulators

Typical Operating Characteristics

(Typical values are: $V_{IN} = +1.8V$, $V_{OUT} = +1.5V$, $I_{OUT} = 2A$, $C_{OUT} = 10\mu F$, $C_{IN} = 2.2\mu F$, and $T_A = +25^\circ C$, unless otherwise noted.)

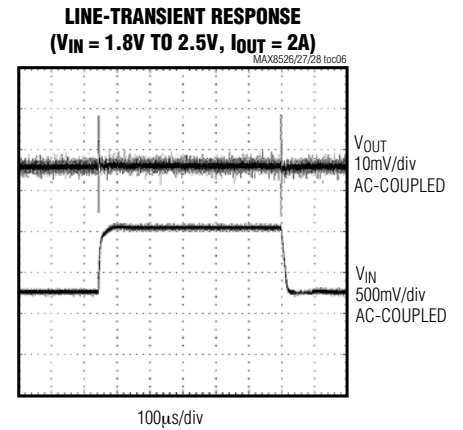
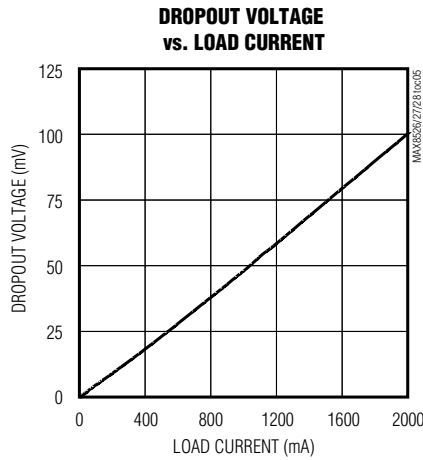
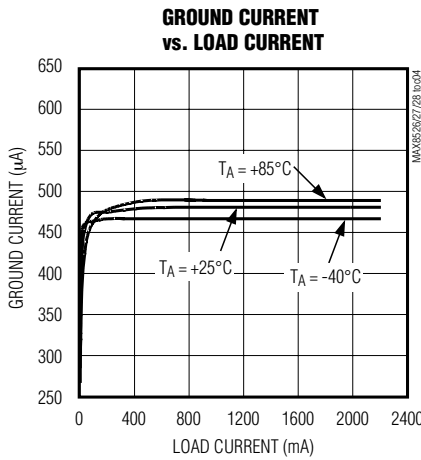
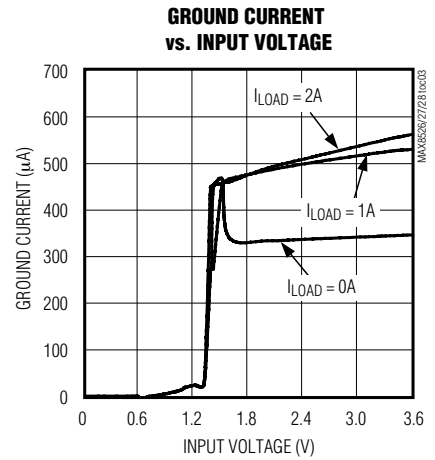
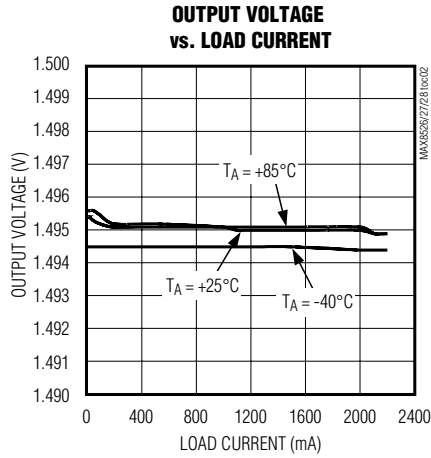
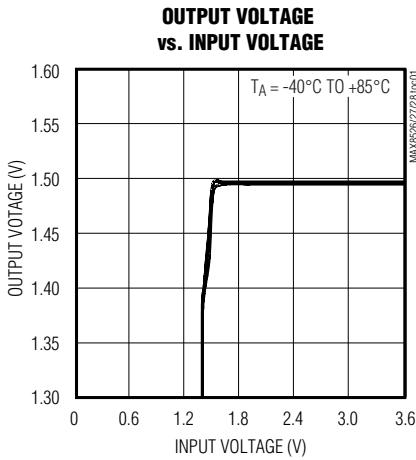

LOAD-TRANSIENT RESPONSE
($I_{LOAD} = 0.2A$ TO $2.2A$; $C_{IN} = 220\mu F$ ELECTROLYTIC CAP CLOSE TO IN)

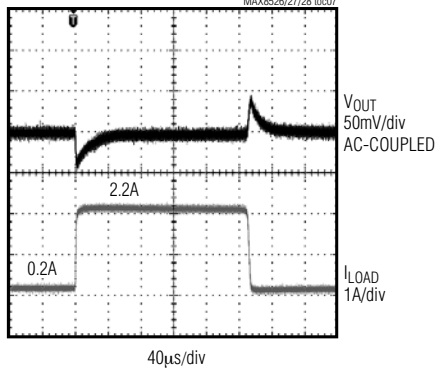

SHUTDOWN RESPONSE

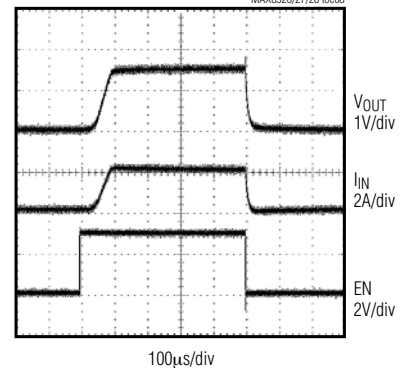

1.425V to 3.6V Input, 2A, 0.2V Dropout LDO Regulators

MAX8526/MAX8527/MAX8528

Typical Operating Characteristics (continued)

(Typical values are: $V_{IN} = +1.8V$, $V_{OUT} = +1.5V$, $I_{OUT} = 2A$, $C_{OUT} = 10\mu F$, $C_{IN} = 2.2\mu F$, and $T_A = +25^\circ C$, unless otherwise noted.)

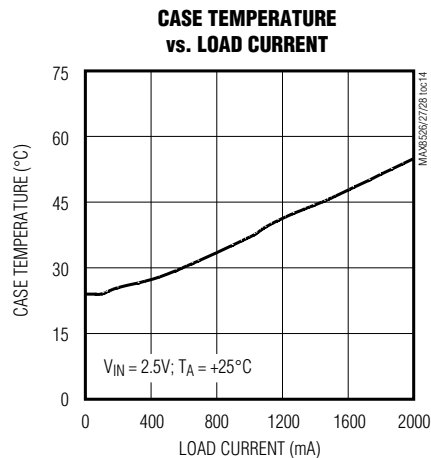
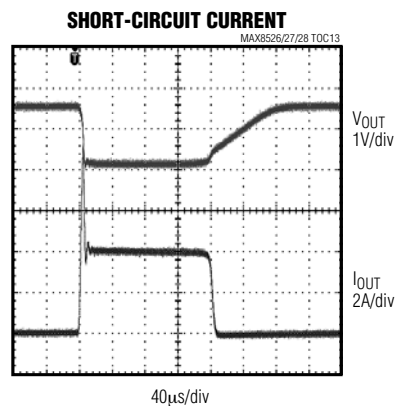
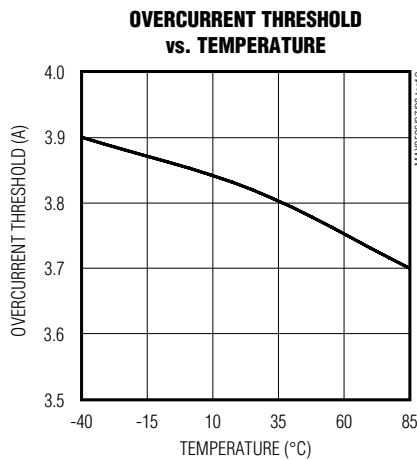
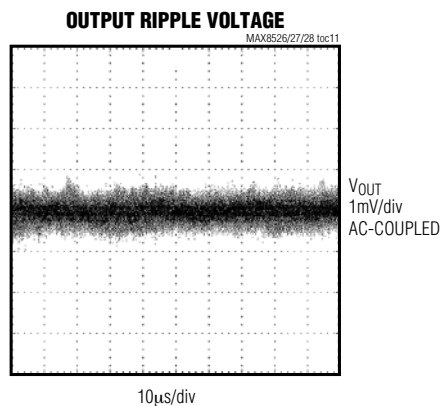
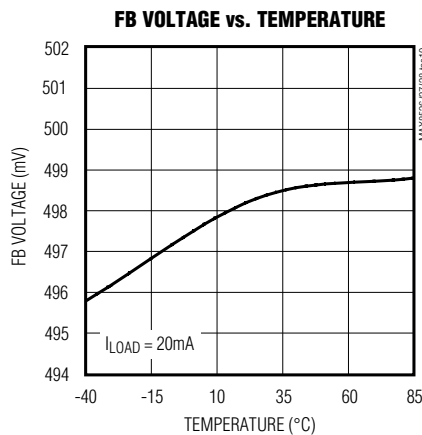
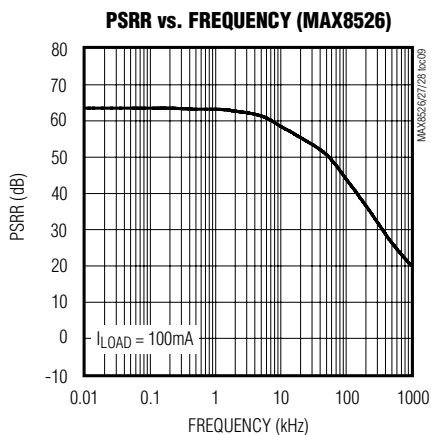

1.425V to 3.6V Input, 2A, 0.2V Dropout LDO Regulators

Pin Description

PIN			NAME	DESCRIPTION
MAX8526	MAX8527	MAX8528		
1	1	1	EN	Enable Input. Set low to place the device in low-current shutdown mode. Set high for normal operation.
2-5	2-5	2-5	IN	Regulator Input. V_{IN} can range from 1.425V to 3.6V. Bypass with a 2.2 μ F or higher ceramic capacitor to GND.
6, 7, 14	7, 14	6, 14	T.P.	Test Pin
8	8	8	GND	Ground
9	9	9	FB	Feedback Pin. Connect to output through a voltage-divider to set the output.
10-13	10-13	10-13	OUT	Regulator Output. Bypass with a 10 μ F ceramic capacitor to GND (a smaller capacitor can be used if maximum load is less than 2A, i.e., $C_{OUT} = I_{OUT}(\max) \times (1\mu\text{F}/200\text{mA})$).
—	6	—	POK	Power-OK Output (MAX8527 Only). Open-drain output. Connect to a positive supply with a pullup resistor. If not used, leave pin unconnected. See the <i>Detailed Description</i> for more details.
—	—	7	POR	Power-On Reset Output. Open-drain output. Connect to a positive supply with a pullup resistor. If not used, leave pin unconnected. See the <i>Detailed Description</i> for more details.
Exposed Pad			—	Exposed Pad on the Underside of the Package. Solder to the ground plane for proper heat dissipation.

Functional Diagram

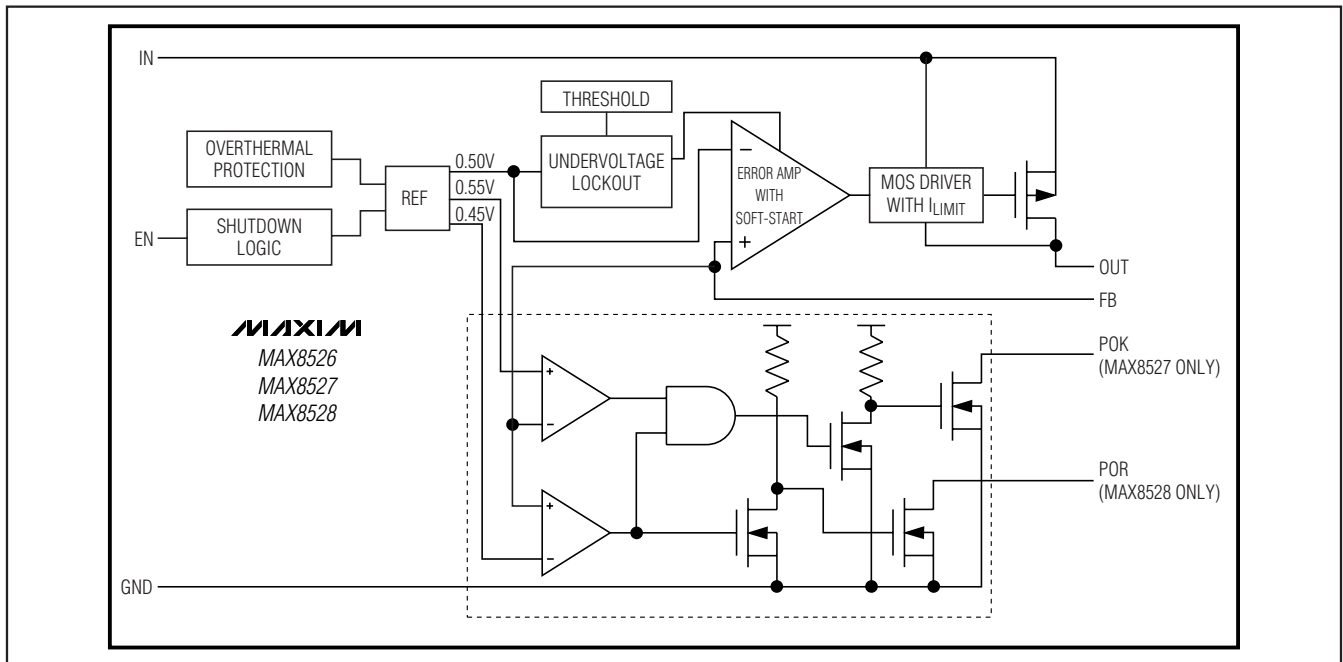

1.425V to 3.6V Input, 2A, 0.2V Dropout LDO Regulators

Detailed Description

The MAX8526/MAX8527/MAX8528 are low-input, low-dropout, PMOS regulators capable of delivering up to 2A of output current with as little as 200mV of headroom from input to output. The PMOS output stage can be driven from input voltages down to +1.425V without sacrificing stability or transient performance. Since this regulator has a PMOS output device, supply current is not a significant function of load or input headroom.

Internal P-Channel Pass Transistor

The MAX8526/MAX8527/MAX8528 feature a 50mΩ (typ) P-channel MOSFET pass transistor. Unlike similar designs using PNP pass transistors, P-channel MOSFETs require no base drive, which reduces quiescent current. PNP-based regulators also waste considerable current in dropout when the pass transistor saturates, and use high base-drive currents under large loads. The MAX8526/MAX8527/MAX8528 do not suffer from these problems and consume only 500μA (typ) of quiescent current under heavy loads, as well as in dropout.

Short-Circuit/Thermal Fault Protection

The MAX8526/MAX8527/MAX8528 are fully protected from a short circuit at the output through current-limiting and thermal-overload circuitry. In the fault condition when the output is shorted to ground, the output current is limited to 4A. Under these conditions, the part quickly heats up. When the junction temperature reaches +165°C, the thermal-overload circuitry turns off the output, allowing the part to cool down. When the junction temperature cools to +150°C, the output turns back on and tries to reestablish regulation. Current limiting and thermal protection continue until the fault is removed. For continuous operation, do not exceed the absolute maximum junction temperature rating of $T_J = +150^\circ\text{C}$.

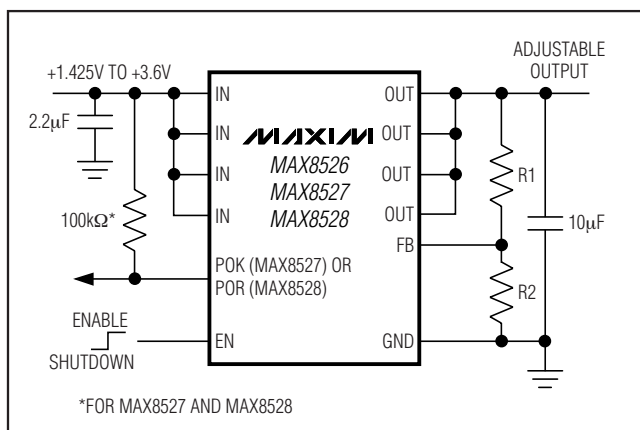

Figure 1. Typical Application Circuit

Output Voltage Selection

The MAX8526/MAX8527/MAX8528 feature an adjustable output voltage from 0.5V to 3.4V, using two external resistors connected as a voltage-divider to FB as shown in Figure 1. The output voltage is set by the following equation:

$$V_{OUT} = V_{FB} \left(1 + \frac{R1}{R2} \right)$$

where typically $V_{FB} = 0.5\text{V}$. Choose $R2 \leq 5\text{k}\Omega$ to optimize quiescent current, accuracy, and high-frequency power-supply rejection. To simplify resistor selection:

$$R1 = R2 \left(\frac{V_{OUT}}{V_{FB}} - 1 \right)$$

Soft-Start

Inherent soft-start limits inrush current. Peak inrush current is dependent on the value of C_{OUT} and can be calculated as follows:

$$I_{INRUSH} = I_{LOAD} + \left(\frac{C_{OUT}(\mu\text{F})}{66} \right)$$

Shutdown Mode

The MAX8526/MAX8527/MAX8528 include an enable input. To shut down the device, pull EN to GND. For normal operation, connect the EN to IN. During shutdown, an internal 10kΩ resistor pulls down the output.

Power-OK (POK, MAX8527 Only)

The MAX8527 features a power-OK output to indicate the status of the output. POK remains high when the regulator output is within $\pm 10\%$ of its nominal output voltage. If the output voltage falls/rises outside this range, POK transitions low. This open-drain output requires an external pullup resistor to IN. An internal delay circuit prevents the POK from switching for 50μs (typ) after the trip threshold is initially reached. If the part is in shutdown mode, POK is low.

Power-On Reset (POR, MAX8528 Only)

The MAX8528 features a power-on reset output that transitions high 150ms (typ) after the output has risen above 90% of its final value. This open-drain output requires an external pullup resistor to IN. If the part is in shutdown mode, falls below 90% of the nominal output voltage, or experiences a short-circuit/thermal fault, POR immediately transitions low.

1.425V to 3.6V Input, 2A, 0.2V Dropout LDO Regulators

Operating Region and Power Dissipation

The maximum power dissipation depends on the thermal resistance of the IC package and circuit board, the temperature difference between the die junction and ambient air, and the rate of airflow. The power dissipated in the device is $P = I_{OUT} \times (V_{IN} - V_{OUT})$.

The package features an exposed thermal pad on its underside. This pad lowers the thermal resistance of the package by providing a direct heat conduction path from the die to the PC board.

Additionally, the ground pins (GND) perform the dual function of providing an electrical connection to system ground and channeling heat away. Connect the exposed backside pad and GND to the system ground using a large pad or ground plane, or multiple vias to the ground-plane layer.

Applications Information

Capacitor Selection and Regulator Stability

Capacitors are required at the MAX8526/MAX8527/MAX8528 inputs and outputs for stable operation over the full temperature range and with load currents up to 2A. Connect a 2.2µF capacitor between IN and ground and a 10µF capacitor with low equivalent-series-resistance (ESR) capacitor between OUT and ground for 2A

output current. The input capacitor (C_{IN}) lowers the source impedance of the input supply. If input-supply source impedance is high, place a larger input capacitor close to IN to prevent V_{IN} sagging due to load transients. Smaller output capacitors can be used for output currents less than 2A. Calculate C_{OUT} as follows:

$$C_{OUT} = I_{OUT(max)} \times (1\mu F / 200mA)$$

Noise, PSRR, and Transient Response

The MAX8526/MAX8527/MAX8528 are designed to operate with low dropout voltages and low quiescent currents, while still maintaining good noise, transient response, and AC rejection. See the *Typical Operating Characteristics* for a plot of Power-Supply Rejection Ratio (PSRR) vs. Frequency. When operating from noisy sources, improved supply-noise rejection and transient response can be achieved by increasing the values of the input and output bypass capacitors and through passive filtering techniques. The MAX8526/MAX8527/MAX8528 load-transient response graphs (see the *Typical Operating Characteristics*) show two components of the output response: a DC shift from the output impedance due to the load current change, and the transient response. A typical transient overshoot for a step change in the load current from 20mA to 2A is 45mV. Use larger output ceramic capacitors greater than 10µF up to 100µF to attenuate the overshoot.

Pin Configurations

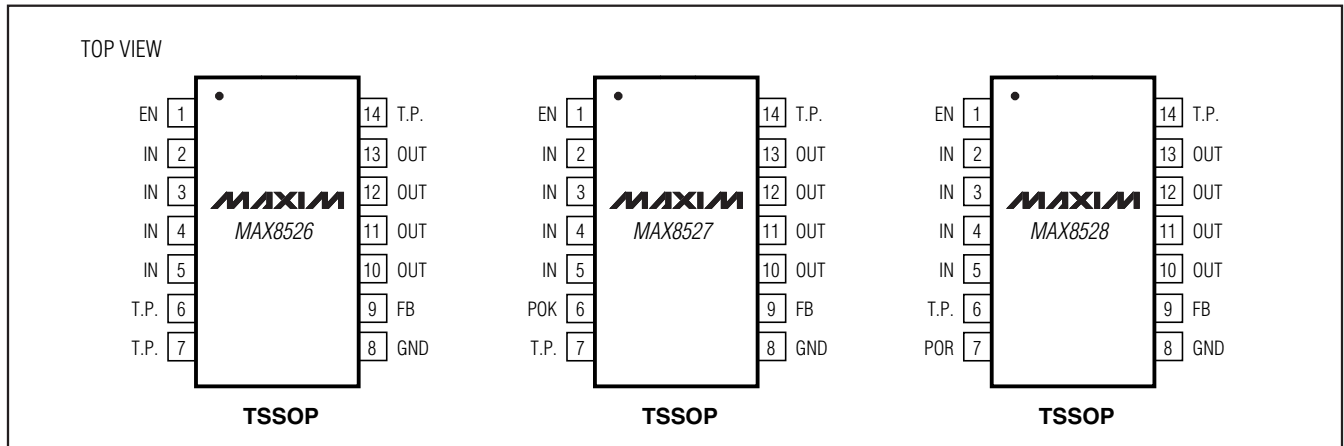

Chip Information

TRANSISTOR COUNT: 2977

PROCESS: BiCMOS

1.425V to 3.6V Input, 2A, 0.2V Dropout LDO Regulators

Package Information

(The package drawing(s) in this data sheet may not reflect the most current specifications. For the latest package outline information go to www.maxim-ic.com/packages.)

MAX8526/MAX8527/MAX8528

COMMON DIMENSIONS

SYMBOL	MILLIMETERS		INCHES	
	MIN.	MAX.	MIN.	MAX.
A	--	1.10	--	0.043
A1	0.05	0.15	0.002	0.006
A2	0.85	0.95	0.033	0.037
b	0.19	0.30	0.007	0.012
b1	0.19	0.25	0.007	0.010
c	0.090	0.20	0.004	0.008
c1	0.090	0.135	0.004	0.0053
D	SEE VARIATIONS		SEE VARIATIONS	
E	4.30	4.50	0.169	0.177
e	0.65 BSC		0.026 BSC	
H	6.25	6.50	0.246	0.256
L	0.50	0.70	0.020	0.028
N	SEE VARIATIONS		SEE VARIATIONS	
Y	2.85	3.15	0.112	0.124
α	0°		8°	
PKG. CODES	U14E-3; U16E-3; U20E-1; U20E-4; U28E-4; U28E-5			

JEDEC	N	VARIATIONS				
		MILLIMETERS		INCHES		
MO-153	N					
		MIN.	MAX.	MIN.	MAX.	
ABT-1	14	D	4.90	5.10	0.193	0.201
		X	2.95	3.25	0.116	0.128
ABT	16	D	4.90	5.10	0.193	0.201
		X	2.85	3.15	0.112	0.124
ACT	20	D	6.40	6.60	0.252	0.260
		X	4.00	4.34	0.157	0.171
AET	28	D	9.60	9.80	0.378	0.386
		X	5.35	5.65	0.211	0.222

NOTES:

- DIMENSIONS D AND E DO NOT INCLUDE FLASH.
- MOLD FLASH OR PROTRUSIONS NOT TO EXCEED 0.15mm PER SIDE.
- CONTROLLING DIMENSION: MILLIMETERS.
- MEETS JEDEC OUTLINE MO-153. SEE JEDEC VARIATIONS TABLE.
- 'N' REFERS TO NUMBER OF LEADS.
- EXPOSED PAD FLUSH WITH BOTTOM OF PACKAGE WITHIN .002".
- THE LEAD TIPS MUST LIE WITHIN A SPECIFIED ZONE. THIS TOLERANCE ZONE IS DEFINED BY TWO PARALLEL PLANES. ONE PLANE IS THE SEATING PLANE, DATUM [-C-]; THE OTHER PLANE IS AT THE SPECIFIED DISTANCE FROM [-C-] IN THE DIRECTION INDICATED.
- MARKING IS FOR PACKAGE ORIENTATION REFERENCE ONLY.
- NUMBER OF LEADS SHOWN ARE FOR REFERENCE ONLY.
- ALL DIMENSIONS APPLY TO BOTH LEADED (-) AND PbFREE (+) PKG. CODES.

-DRAWING NOT TO SCALE-

MAXIM

TITLE:
PACKAGE OUTLINE,
TSSOP 4.4mm BODY, EXPOSED PAD

APPROVAL: _____ DOCUMENT CONTROL NO. 21-0108 REV. F 1/1

Maxim cannot assume responsibility for use of any circuitry other than circuitry entirely embodied in a Maxim product. No circuit patent licenses are implied. Maxim reserves the right to change the circuitry and specifications without notice at any time.